

Hyperfilter BioEnergy

Filters for Biogas & Landfill Gas Applications



Biogas produced in anaerobic digesters and landfills is saturated with water and contains foams, small solid particles in suspension, greases, particulates and other contaminants: it is therefore essential that these contaminants are removed from the gas by filtration prior to any downstream equipment or pipework.

Failure to remove these impurities may lead to a malfunction of devices and processes downstream and, in the absence of effective dehumidification, can cause clogging or blocking of blowers, heat exchangers and gas meters increasing maintenance costs and plant downtime.

Hyperfilter BioEnergy has been specifically designed to prevent these undesired effects, available in a range of sizes matched to the needs of biogas applications. The secret of Hyperfilter BioEnergy is its highly advanced filter element. This combines ultra-high particle retention efficiency with extremely low pressure drop which results in clean, ready to use biogas with service costs kept to a minimum.



Features & Benefits:

- High-Efficiency filtration media which provides maximum protection for downstream equipment and pipework significantly reducing maintenance costs and plant downtime;
- Stainless steel housing materials (AISI304 or AISI316L) with pickling and passivation treatment in order to ensure highly reliable and continuous operation even in the harshest conditions typically experienced in a biogas plant or a landfill;
- Designed using fluid dynamic principles to ensure high efficiency filtration whilst maintaining a very low pressure drop;
- Range of sizes to cover biogas flow rates from 105 to 3180 m³/h (larger sizes available on request);
- Supplied complete with support legs for easy installation and mounting;
- Top access cover to enable quick and easy element replacement

Product-Specification

Hyperfilter BioEnergy FFB 105-3180

Hyperfilter Bioenergy is formed by a stainless steel AISI304 or AISI316L vessel with flanged cover and two flanged pipe connections for biogas inlet and outlet. The filter base acts as a trap for water and other contaminants which can then effectively removed by the manual drain valve. Two threaded etchings are provided to make possible the connection of a differential pressure gauge.

Filtration takes place through a porous filter element made of antistatic, spunbonded polyester to ensure optimum filtration efficiency and high stability. Surface electrical conductivity of the filter media is attained through the application of aluminum powders: this treatment is the best solution for all applications requiring

elimination of electrical charges created on the particles to be filtered and therefore on the filter media, in compliance with ATEX regulations.

Filtration quality is 5 μm or 20 μm .

Operation

- ① The biogas enters the filter.
- ② The biogas passes through the filter element, which holds virtually all solid and liquid particles with a size higher than 5 μm and 20 μm .
- ③ The filtered liquid and solid particles drop to the bottom of the filter.
- ④ The filtered biogas exits the filter.

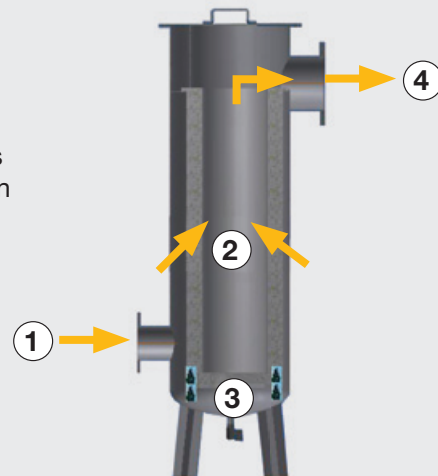

To maintain optimum and effective filtration, filter elements must be replaced at least every 6 months with genuine Parker Hiross parts. Half-year filter elements changes are therefore essential and ensure:

- Optimal performance is maintained
- High filtration quality
- Low operational costs
- Continued protection of downstream equipment & processes

Failure to perform the scheduled replacement can lead to increasing system pressure drops.

Product-Specification

Hyperfilter BioEnergy FFB 105-3180

Area of Application Filter

Standard Filter	Biogas, Landfill Gas and Natural Gas
Max operating pressure	0,5 barg
Operating Temperature	-10°C up to 100°C

Performance Data Element

Removal	Pollutants, foams, particulate and separation of residual moisture
Flow Direction	from outside to inside
Particle removal size	5 µm / 20 µm
Filtration Efficiency	99,999%
Differential pressure,dry	2 mbar

Material housing

Housing body	Stainless steel: parts in contact with biogas in AISI304 or AISI316L, not in contact in AISI304
Surface treatment	Pickling and passivation
Gaskets	Mineral fibers with NBR binder

Material Elements

End caps	Stainless steel
Inner core	Perforated stainless steel
Filter medium	260g antistatic polyester spunbonded
Sealing	Epoxy resin
Gaskets	Neoprene

A stainless steel grounding wire is mounted underneath the top ring alongside the filter medium

Technical data and measurements

Model	Gasflow*		Connections		Filter elements
	m ³ /min	m ³ /h	IN	OUT	Quantity
FFB105	1,8	105	DN50	DN80	1
FFB265	4,4	265	DN80	DN125	1
FFB720	12,0	720	DN125	DN200	1
FFB1110	18,5	1110	DN200	DN300	1
FFB3180	41,7	2500	DN300	DN450	1

Dimensions (mm)				Weight
A	B	C	D	kg
440	1454	1330	420	32
440	1424	1300	390	35
625	1838	1595	545	99
633	1883	1650	600	108
1000	2208	1805	696	255

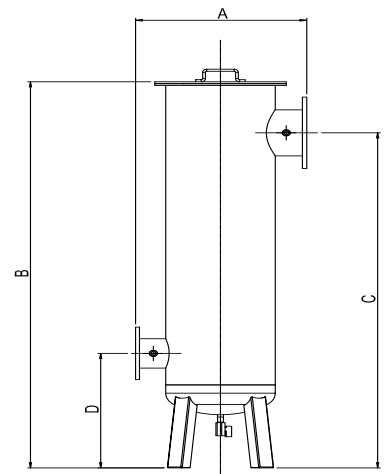

*Nominal working conditions: gas inlet temperature 40 °C, atmospheric pressure, 60 %CH₄ 40 %CO₂, pressure drop 3 mbar. FFB Filters can work at higher gas flow rates with an increase in pressure drop (refer to Parker Hiross)

Parker Worldwide

Europe, Middle East, Africa

AE – United Arab Emirates, Dubai

Tel: +971 4 8127100
parker.me@parker.com

AT – Austria, Wiener Neustadt

Tel: +43 (0)2622 23501-0
parker.austria@parker.com

AT – Eastern Europe, Wiener Neustadt

Tel: +43 (0)2622 23501 900
parker.easteurope@parker.com

AZ – Azerbaijan, Baku

Tel: +994 50 2233 458
parker.azerbaijan@parker.com

BE/LU – Belgium, Nivelles

Tel: +32 (0)67 280 900
parker.belgium@parker.com

BY – Belarus, Minsk

Tel: +375 17 209 9399
parker.belarus@parker.com

CH – Switzerland, Etoy

Tel: +41 (0)21 821 87 00
parker.switzerland@parker.com

CZ – Czech Republic, Klecany

Tel: +420 284 083 111
parker.czechrepublic@parker.com

DE – Germany, Kaarst

Tel: +49 (0)2131 4016 0
parker.germany@parker.com

DK – Denmark, Ballerup

Tel: +45 43 56 04 00
parker.denmark@parker.com

ES – Spain, Madrid

Tel: +34 902 330 001
parker.spain@parker.com

FI – Finland, Vantaa

Tel: +358 (0)20 753 2500
parker.finland@parker.com

FR – France, Contamine s/Arve

Tel: +33 (0)4 50 25 80 25
parker.france@parker.com

GR – Greece, Athens

Tel: +30 210 933 6450
parker.greece@parker.com

HU – Hungary, Budapest

Tel: +36 23 885 475
parker.hungary@parker.com

IE – Ireland, Dublin

Tel: +353 (0)1 466 6370
parker.ireland@parker.com

IT – Italy, Corsico (MI)

Tel: +39 02 45 19 21
parker.italy@parker.com

KZ – Kazakhstan, Almaty

Tel: +7 7272 505 800
parker.easteurope@parker.com

NL – The Netherlands, Oldenzaal

Tel: +31 (0)541 585 000
parker.nl@parker.com

NO – Norway, Asker

Tel: +47 66 75 34 00
parker.norway@parker.com

PL – Poland, Warsaw

Tel: +48 (0)22 573 24 00
parker.poland@parker.com

PT – Portugal, Leca da Palmeira

Tel: +351 22 999 7360
parker.portugal@parker.com

RO – Romania, Bucharest

Tel: +40 21 252 1382
parker.romania@parker.com

RU – Russia, Moscow

Tel: +7 495 645-2156
parker.russia@parker.com

SE – Sweden, Spånga

Tel: +46 (0)8 59 79 50 00
parker.sweden@parker.com

SK – Slovakia, Banská Bystrica

Tel: +421 484 162 252
parker.slovakia@parker.com

SL – Slovenia, Novo Mesto

Tel: +386 7 337 6650
parker.slovenia@parker.com

TR – Turkey, Istanbul

Tel: +90 216 4997081
parker.turkey@parker.com

UA – Ukraine, Kiev

Tel: +380 44 494 2731
parker.ukraine@parker.com

UK – United Kingdom, Warwick

Tel: +44 (0)1926 317 878
parker.uk@parker.com

ZA – South Africa, Kempton Park

Tel: +27 (0)11 961 0700
parker.southafrica@parker.com

North America

CA – Canada, Milton, Ontario

Tel: +1 905 693 3000

US – USA, Cleveland

Tel: +1 216 896 3000

Asia Pacific

AU – Australia, Castle Hill

Tel: +61 (0)2-9634 7777

CN – China, Shanghai

Tel: +86 21 2899 5000

HK – Hong Kong

Tel: +852 2428 8008

IN – India, Mumbai

Tel: +91 22 6513 7081-85

JP – Japan, Tokyo

Tel: +81 (0)3 6408 3901

KR – South Korea, Seoul

Tel: +82 2 559 0400

MY – Malaysia, Shah Alam

Tel: +60 3 7849 0800

NZ – New Zealand, Mt Wellington

Tel: +64 9 574 1744

SG – Singapore

Tel: +65 6887 6300

TH – Thailand, Bangkok

Tel: +662 186 7000-99

TW – Taiwan, Taipei

Tel: +886 2 2298 8987

South America

AR – Argentina, Buenos Aires

Tel: +54 3327 44 4129

BR – Brazil, Sao Jose dos Campos

Tel: +55 800 727 5374

CL – Chile, Santiago

Tel: +56 2 623 1216

MX – Mexico, Apodaca

Tel: +52 81 8156 6000